



**Next
Level**
ELEVATORS

ELTEC ACCESS



The Elevator Specialists

We're passionate about supplying Australians with the most beautiful and functional all-electric elevators. As innovators in this space for more than 10 years, we have exclusive access to the best electric lifts from our Italian manufacturer, Eltec. Our superior, more eco-friendly elevators are known for their reliability.

Join us as we continue to redefine the elevator industry in Australia.



P R E M I U M

S E R V I C E



Latest Technology

Our industry-leading elevators are made with the latest cutting-edge technology.



Safety

Our elevators meet the strictest safety standards.



Environmental

Our range includes fully electric, eco-friendly, and cost-efficient elevators.



Experience

Our group has installed thousands of lifts across Australia.



Quick Installation

You can rely on our team for a quick and seamless installation process.



Full Service

From manufacturing, through to installation and ongoing maintenance, we provide a complete elevator service.

Eltec Access

The versatile Eltec Access series adheres to BCA/NCC standards. These elevators are designed with wheelchair access in mind and are suitable for restricted use applications.



Electric Elevator / European A-Grade Energy Class

Wheelchair capacity



BCA + NCC Compliant

Sliding door options

Note: The Eltec Access is not a general passenger elevator.

Applications

The Eltec Access series is an exceptional option for low-traffic commercial spaces and offers flexible solutions for businesses, builders and architects. We recommend the Eltec Access series for use in the following applications:

- Medical Offices
- Childcare Centres
- Schools
- Commercial Offices

General Specification Information

Regulations	Australian Design Registration
Drive System	VVVF all-electric traction system
Country of Origin	Manufactured in Italy
Capacity	400–450 kg (wheelchair capacity)
Maximum Travel	12 m
Number of Stops	6
Maximum Speed	0.3 m/s
Pit Depth	180–200 mm (reduced size upon request)
Headroom	2520–2600 mm (reduced size upon request)
Motor Room	Motor and controller housed within shaft
Power	Single phase / 230 V 10 A



AU Shaft

The following specification details are for the Eltec Access within an AU Shaft. Sold separately, the AU shaft helps avoid shaft-building errors and rectification work. The AU shaft is a self-supporting structure and doesn't require a structural wall, making it an exceptional option for both new builds and retrofits. Do not build to these specifications.

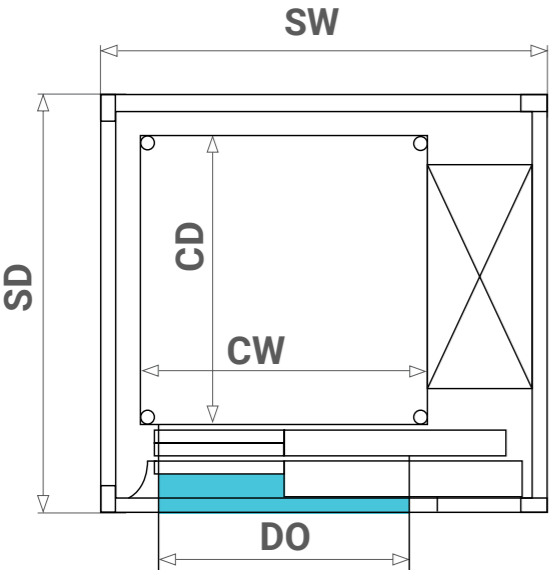

Single Entry Configuration (AU Shaft)

	SW	SD	CW	CD	DO
XL	1700	1830	1100	1400	900
XXL	1800	1880	1200	1450	900

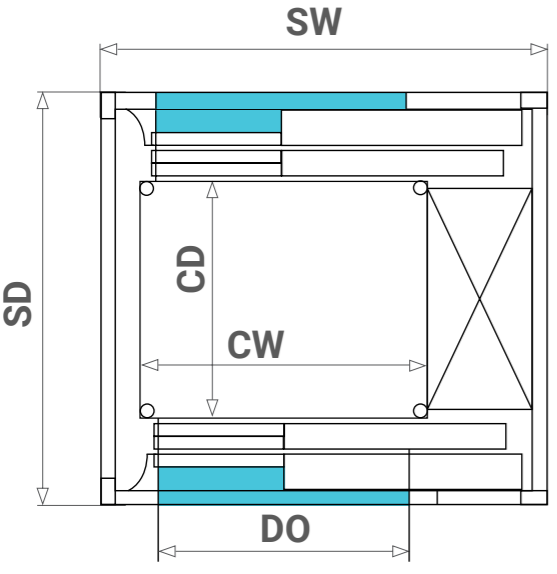

Through Cart Configuration (AU Shaft)

	SW	SD	CW	CD	DO
XL	1720	2004	1100	1420	900
XXL	1820	2054	1200	1470	900

Masonry Shaft

The following specification details are for the Eltec Access within a masonry shaft. Next Level Elevators will provide specific plans per project. Do not build to these specifications.

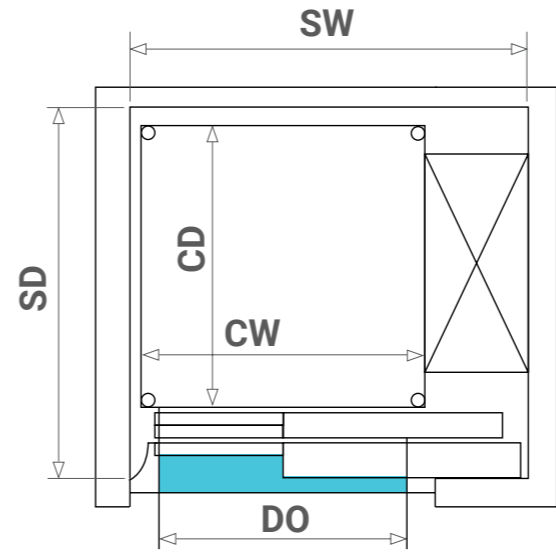

Single Entry Configuration (Masonry Shaft)

	SW	SD	CW	CD	DO
XL	1550	1750	1100	1400	900
XXL	1650	1800	1200	1450	900

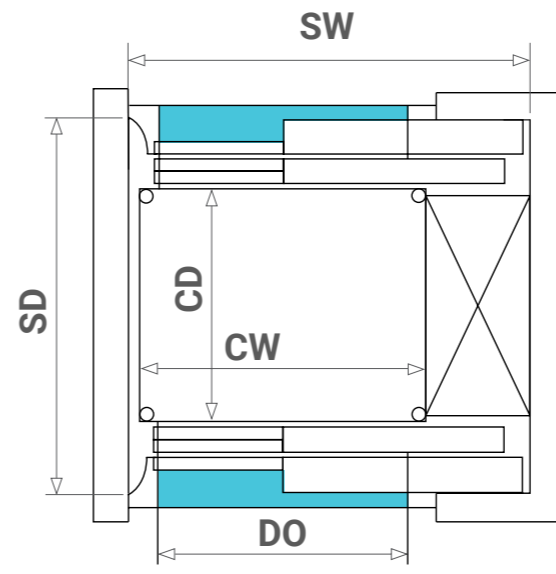

Through Cart Configuration (Masonry Shaft)

	SW	SD	CW	CD	DO
XL	1550	1890	1100	1420	900
XXL	1650	1940	1200	1470	900



*Example with dispensation.

MADE IN ITALY



Melbourne Showroom

456 Smith Street
Collingwood VIC 3066

Sydney Showroom

647 Botany Road
Rosebery NSW 2018

Queensland

PO Box 6347
Meridan Plains QLD 4551